



Austrian Institute of Construction Engineering  
Schenkenstrasse 4 | T+43 1 533 65 50  
1010 Vienna | Austria | F+43 1 533 64 23  
www.oib.or.at | mail@oib.or.at



# European Technical Assessment

**ETA-20/0860**  
of 27.03.2023

General part

**Technical Assessment Body issuing the European Technical Assessment**

Österreichisches Institut für Bautechnik (OIB)  
Austrian Institute of Construction Engineering

**Trade name of the construction product**

HBS Brettsper Holz

**Product family to which the construction product belongs**

Solid wood slab elements to be used as structural elements in buildings

**Manufacturer**

HBS Berga GmbH & Co. KG  
Ahornweg 1  
06536 Berga  
Germany

**Manufacturing plant**

Ante-Gruppe  
Im Inkerfeld 1  
35108 Allendorf (Eder) - Somplar  
Germany

HBS Berga GmbH & Co. KG  
Ahornweg 1  
06536 Berga  
Germany

**This European Technical Assessment contains**

19 pages including 5 Annexes which form an integral part of this assessment.

**This European Technical Assessment is issued in accordance with Regulation (EU) No 305/2011, on the basis of**

European Assessment Document (EAD)  
130005-00-0304 "Solid wood slab element to be used as a structural element in buildings".

**This European Technical Assessment replaces**

European Technical Assessment ETA-20/0860 of 26.04.2022.

## Remarks

Translations of this European Technical Assessment in other languages shall fully correspond to the original issued document and should be identified as such.

Communication of this European Technical Assessment, including transmission by electronic means, shall be in full. However, partial reproduction may be made with the written consent of Austrian Institute of Construction Engineering. Any partial reproduction has to be identified as such.

Specific parts

### 1 Technical description of the product

#### 1.1 General

This European Technical Assessment (ETA)<sup>1</sup> applies to the cross laminated timber “HBS Brettsperrholz”. HBS Brettsperrholz is made of softwood boards which are bonded together in order to form cross laminated timber (solid wood slab elements). Generally, adjacent layers of the softwood boards are arranged perpendicular (angle of 90°) to each other, see Annex 1, Figure 1.

The principle structure of the cross laminated timber is shown in Annex 1, Figure 2 and Figure 3. Surfaces are planed. In addition two vertical grooves may be arranged in longitudinal direction of the boards, with a maximum depth of half of the board thickness and a width of 4 mm. Figure 4 shows the geometry of the vertical grooves.

The solid wood slab elements consist of at least three and up to fifteen adjacent layers which are arranged perpendicular to each other. With regard to the thickness of the solid wood slab element, thickness and orientation of individual layers are symmetrically assembled. In case of serious deviations from symmetry potential effects should be investigated.

A maximum of three adjacent layers may be arranged in the same direction as long as a symmetric cross-section with cross-layering remains and their all over thickness does not exceed 90 mm.

Single board layers (maximum 50 % of the cross section) may be replaced by one- and multilayer solid wood panels. The solid wood panels shall be suitable for structural use.

The surfaces of the solid wood slabs may be covered with additional layers. This panels are not part of this European Technical Assessment. Strength and stiffness characteristics for mechanical actions perpendicular to and in plane of the cross laminated timber are only assigned to the cross laminated timber without covering.

HBS Brettsperrholz and the boards for its manufacturing correspond to the specifications given in the Annexes 1 and 2. The material characteristics, dimensions and tolerances of HBS Brettsperrholz, not indicated in these Annexes, are given in the technical file<sup>2</sup> of the European Technical Assessment.

The application of wood preservatives and flame retardants is not subject of the European Technical Assessment.

<sup>1</sup> In 2020 ETA-20/0860 was firstly issued as European Technical Assessment ETA-20/0860 of 10.12.2020, 2022 amended to ETA-20/0860 of 26.04.2022 and 2023 amended to ETA-20/0860 of 27.03.2023.

<sup>2</sup> The technical file of the European Technical Assessment is deposited at Österreichisches Institut für Bautechnik and, in so far as is relevant to the tasks of the notified product certification body involved in the assessment and verification of constancy of performance procedure, is handed over to the notified product certification body.

## 1.2 Components

### 1.2.1 Boards

The specification of the boards is given in Annex 2, Table 2. Boards are visually or machine strength graded. Only technically dried wood shall be used. In addition two vertical grooves may be arranged in longitudinal direction of the boards, with a maximum depth of half of the board thickness and a width of 4 mm.

Wood species is European spruce or equivalent softwood.

### 1.2.2 Adhesive

The adhesive for bonding of the cross laminated timber and the finger joints of the individual boards shall conform to EN 301 or EN 15425.

Normally a PU adhesive is used.

### 1.2.3 Solid wood panels

The specification of the solid wood panels is given in Annex 2, Table 2. One- and multilayer solid wood panels are in accordance with EN 13986 or a European Technical Assessment.

## 2 Specification of the intended use(s) in accordance with the applicable European Assessment Document (thereafter EAD)

### 2.1 Intended use

The solid wood slab is intended to be used as a structural or non-structural element in buildings and timber structures.

The solid wood slab shall be subjected to static and quasi-static actions (not relevant for fatigue) only.

The solid wood slab is intended to be used in service classes 1 and 2 according to EN 1995-1-1<sup>3</sup>. Members which are directly exposed to the weather shall be provided with an effective protection for the solid wood slab element in service.

### 2.2 General assumptions

The solid wood slab elements are manufactured in accordance with the provisions of the European Technical Assessment using the manufacturing process as identified in the inspection of the manufacturing plant by Österreichisches Institut für Bautechnik and laid down in the technical file.

The manufacturer shall ensure that the requirements in accordance with the Clauses 1, 2 and 3 as well as with the Annexes of the European Technical Assessment are made known to those who are concerned with design and execution of the works.

Layers of planed boards shall be bonded together to the required thickness of the cross laminated timber. The individual boards shall be jointed in longitudinal direction by means of finger joints according to EN 14080, there shall be no butt joints.

Adhesive shall be applied on one face of each board. The edges of the boards need not to be bonded.

#### Design

The European Technical Assessment only applies to the manufacture and use of cross laminated timber. Verification of stability of the works including application of loads on the cross laminated timber is not subject to the European Technical Assessment.

<sup>3</sup> Reference documents are listed in Annex 5.

The following conditions shall be observed:

- Design of cross laminated timber members is carried out under the responsibility of an engineer experienced in such products.
- Design of the works shall account for the protection of the cross laminated timber.
- The cross laminated timber members are installed correctly.

Design of cross laminated timber members elements may be according to EN 1995-1-1 and EN 1995-1-2, taking into account of Annexes 2 and 3 of the European Technical Assessment.

Standards and regulations in force at the place of use shall be considered.

#### Packaging, transport, storage, maintenance, replacement and repair

Concerning product packaging, transport, storage, maintenance, replacement and repair it is the responsibility of the manufacturer to undertake the appropriate measures and to advise his clients on the transport, storage, maintenance, replacement and repair of the product as he considers necessary.

#### Installation

It is assumed that the product will be installed according to the manufacturer's instructions or (in absence of such instructions) according to the usual practice of the building professionals.

### **2.3 Assumed working life**

The provisions made in the European Technical Assessment (ETA) are based on an assumed intended working life of HBS Brettsperrholz of 50 years, when installed in the works, provided that the cross laminated timber elements are subject to appropriate installation, use and maintenance (see Clause 2.2). These provisions are based upon the current state of the art and the available knowledge and experience<sup>4</sup>.

The indications given as to the working life of the construction product cannot be interpreted as a guarantee neither given by the product manufacturer or his representative nor by EOTA nor by the Technical Assessment Body, but are regarded only as a means for choosing the appropriate products in relation to the expected economically reasonable working life of the works.

---

<sup>4</sup> The real working life of a product incorporated in a specific works depends on the environmental conditions to which that works is subject, as well as on the particular conditions of the design, execution, use and maintenance of that works. Therefore, it cannot be excluded that in certain cases the real working life of the product can also be shorter than the assumed working life.

### 3 Performance of the product and reference to the methods used for its assessment

#### 3.1 Essential characteristics of the product

**Table 1: Essential characteristics of the product and assessment methods**

No	Essential characteristic	Product performance
Basic requirement for construction works 1: Mechanical resistance and stability <sup>1)</sup>		
1	Bending <sup>2)</sup>	Annex 2
2	Tension and compression <sup>2)</sup>	Annex 2
3	Shear <sup>2)</sup>	Annex 2
4	Embedment strength	Annex 2
5	Creep and duration of the load	Annex 2
6	Dimensional stability	Annex 2
7	In-service environment	Annex 2
8	Bond integrity	Annex 2
Basic requirement for construction works 2: Safety in case of fire		
9	Reaction to fire	Annex 2
10	Resistance to fire	Annex 2
Basic requirement for construction works 3: Hygiene, health and the environment		
11	Content, emission and/or release of dangerous substances	3.1.1
12	Water vapour permeability – Water vapour transmission	Annex 2
Basic requirement for construction works 4: Safety and accessibility in use		
13	Impact resistance	Annex 2
Basic requirement for construction works 5: Protection against noise		
14	Airborne sound insulation	No performance assessed.
15	Impact sound insulation	No performance assessed.
16	Sound absorption	No performance assessed.
Basic requirement for construction works 6: Energy economy and heat retention		
17	Thermal conductivity	Annex 2
18	Air permeability	No performance assessed.
19	Thermal inertia	Annex 2
<sup>1)</sup> These characteristics also relate to basic requirement for construction works 4. <sup>2)</sup> Load bearing capacity and stiffness regarding mechanical actions perpendicular to and in plane of the solid wood slab element.		

##### 3.1.1 Hygiene, health and the environment

The release of dangerous substances is determined according to EAD 130005-00-0304, “Solid wood slab element to be used as a structural element in buildings”. No dangerous substances is the performance of the HBS Brettsperholz in this respect.

NOTE In addition to the specific clauses relating to dangerous substances contained in the ETA, there may be other requirements applicable to the products falling within its scope (e.g. transposed European legislation and national laws, regulations and administrative provisions). In order to meet the provisions of the Construction Products Regulation, these requirements need also to be complied with, when and where they apply.

## 3.2 Assessment methods

### 3.2.1 General

The assessment of the essential characteristics in Clause 3.1 of HBS Brettsperrholz for the intended use, and in relation to the requirements for mechanical resistance and stability, for safety in case of fire, for hygiene, health and the environment, for safety and accessibility in use, for protection against noise and for energy economy and heat retention in the sense of the basic requirements for construction works № 1 to 6 of Regulation (EU) № 305/2011 has been made in accordance with the European Assessment Document EAD 130005-00-0304, Solid wood slab element to be used as a structural element in buildings.

### 3.2.2 Identification

The European Technical Assessment for HBS Brettsperrholz is issued on the basis of agreed data that identify the assessed product. Changes to materials, to composition, to characteristics of the product, or to the production process could result in these deposited data being incorrect. Österreichisches Institut für Bautechnik should be notified before the changes are implemented, as an amendment of the European Technical Assessment is possibly necessary.

## 4 Assessment and verification of constancy of performance (thereafter AVCP) system applied, with reference to its legal base

### 4.1 System of assessment and verification of constancy of performance

According to Commission Decision 97/176/EC the system of assessment and verification of constancy of performance to be applied to HBS Brettsperrholz is System 1. System 1 is detailed in Commission Delegated Regulation (EU) № 568/2014 of 18 February 2014, Annex, 1.2., and provides for the following items

- (a) The manufacturer shall carry out
  - (i) factory production control;
  - (ii) further testing of samples taken at the manufacturing plant by the manufacturer in accordance with a prescribed test plan<sup>5</sup>;
- (b) The notified product certification body shall decide on the issuing, restriction, suspension or withdrawal of the certificate of constancy of performance of the construction product on the basis of the outcome of the following assessments and verifications carried out by that body:
  - (i) an assessment of the performance of the construction product carried out on the basis of testing (including sampling), calculation, tabulated values or descriptive documentation of the product;
  - (ii) initial inspection of the manufacturing plant and of factory production control;
  - (iii) continuous surveillance, assessment and evaluation of factory production control.

### 4.2 AVCP for construction products for which a European Technical Assessment has been issued

Notified bodies undertaking tasks under System 1 shall consider the European Technical Assessment issued for the construction product in question as the assessment of the performance of that product. Notified bodies shall therefore not undertake the tasks referred to in point 4.1 (b)(i).

<sup>5</sup> The prescribed test plan has been deposited with Österreichisches Institut für Bautechnik and is handed over only to the notified product certification body involved in the procedure for the assessment and verification of constancy of performance. The prescribed test plan is also referred to as control plan.

## **5 Technical details necessary for the implementation of the AVCP system, as provided for in the applicable European Assessment Document**

### **5.1 Tasks for the manufacturer**

#### **5.1.1 Factory production control**

In the manufacturing plant the manufacturer shall establish and continuously maintain a factory production control. All procedures and specification adopted by the manufacturer shall be documented in a systematic manner. The factory production control shall ensure the constancy of performances of HBS Brettsperrholz with regard to the essential characteristics.

The manufacturer shall only use raw materials supplied with the relevant inspection documents as laid down in the control plan. The incoming raw materials shall be subject to controls by the manufacturer before acceptance. Check of incoming materials shall include control of inspection documents presented by the manufacturer of the raw materials.

The frequencies of controls conducted during manufacturing and on the assembled product are defined by taking account of the manufacturing process of the product and are laid down in the control plan.

The results of factory production control are recorded and evaluated. The records include at least the following data:

- Designation of the product, basic materials and components
- Type of control or test
- Date of manufacture of the product and date of testing of the product or basic materials or components
- Results of controls and tests and, if appropriate, comparison with requirements
- Name and signature of person responsible for factory production control

The records shall be kept at least for ten years time after the construction product has been placed on the market and shall be presented to the notified product certification body involved in continuous surveillance. On request they shall be presented to Österreichisches Institut für Bautechnik.

#### **5.1.2 Declaration of performance**

The manufacturer is responsible for preparing the declaration of performance. When all the criteria of the assessment and verification of constancy of performance are met, including the certificate of conformity issued by the notified product certification body, the manufacturer shall draw up a declaration of performance.

### **5.2 Tasks for the notified product certification body**

#### **5.2.1 Initial inspection of the manufacturing plant and of factory production control**

The notified product certification body shall verify the ability of the manufacturer for a continuous and orderly manufacturing of HBS Brettsperrholz according to the European Technical Assessment. In particular the following items shall be appropriately considered

- Personnel and equipment
- The suitability of the factory production control established by the manufacturer
- Full implementation of the control plan

#### 5.2.2 Continuous surveillance, assessment and evaluation of factory production control

The notified product certification body shall visit the factory at least once a year for routine inspection. In particular the following items shall be appropriately considered

- The manufacturing process including personnel and equipment
- The factory production control
- The implementation of the control plan

The results of continuous surveillance are made available on demand by the notified product certification body to Österreichisches Institut für Bautechnik. When the provisions of the European Technical Assessment and the control plan are no longer fulfilled, the certificate of constancy of performance is withdrawn by the notified product certification body.

Issued in Vienna on 27.03.2023  
by Österreichisches Institut für Bautechnik

The original document is signed by:

Rainer Mikulits  
Managing Director









**Table 3: Product characteristics of the solid wood slab**

BWR	Essential characteristic	Assessment method	Level / Class / Description
1	<b>Mechanical resistance and stability</b>		
	<b>1. Mechanical actions perpendicular to cross laminated timber</b>		
	Strength class of boards	EN 338	C24
	Modulus of elasticity		
	– parallel to the grain of the boards $E_{0, mean}$	$I_{eff}$ , Annex 3 EAD 130005-00-0304, 2.2.1.1	11 600 MPa
	– perpendicular to the grain of the boards $E_{90, mean}$	EN 338	370 MPa
	Shear modulus		
	– parallel to the grain of the boards $G_{090, mean}$	EN 338	690 MPa
	– perpendicular to the grain of the boards (rolling shear modulus) $G_{9090, mean}$	EAD 130005-00-0304, 2.2.1.1	50 MPa
	Bending strength		
– parallel to the grain of the boards $f_{m, k}$	$W_{eff}$ , Annex 3 EAD 130005-00-0304, 2.2.1.1	24 MPa	
Tensile strength			
– perpendicular to the grain of the boards $f_{t, 90, k}$	EN 338, reduced	0.12 MPa	
Compressive strength			
– perpendicular to the grain of the boards $f_{c, 90, k}$	EN 338	2.5 MPa	
Shear strength			
– parallel to the grain of the boards $f_{v, 090, k}$	EN 338	4.0 MPa	
– perpendicular to the grain of the boards (rolling shear strength) $f_{v, 9090, k}$	$A_{gross}$ , Annex 3 EAD 130005-00-0304, 2.2.1.3	0.7 MPa (vacuum press) 1.4 MPa (hydraulic press)	

**HBS Brettsperrholz**

Annex 2

Characteristic data of cross laminated timber

of European Technical Assessment  
ETA-20/0860 of 27.03.2023

BWR	Essential characteristic	Assessment method	Level / Class / Description
1	<b>Mechanical resistance and stability</b>		
	<b>2. Mechanical actions in plane of cross laminated timber</b>		
	Strength class of boards	EN 338	C24
	Modulus of elasticity – parallel to the grain of the boards $E_{0, mean}$	$A_{net}, I_{net}, Annex 3$ EAD 130005-00-0304, 2.2.1.1	11 600 MPa
	Shear modulus – parallel to the grain of the boards $G_{090, mean}$	$A_{net}, Annex 3$ EAD 130005-00-0304, 2.2.1.3	450 MPa (vacuum press) 690 MPa (hydraulic press)
	Bending strength – parallel to the grain of the boards $f_{m, k}$	$W_{net}, Annex 3$ EAD 130005-00-0304, 2.2.1.1	24 MPa
	Tensile strength – parallel to the grain of the boards $f_{t, 0, k}$	EN 338	14 MPa
	Compressive strength – parallel to the grain of the boards $f_{c, 0, k}$	EN 338	21 MPa
	Shear strength – parallel to the grain of the boards $f_{v, 090, k}$	$A_{net}, Annex 3$ EAD 130005-00-0304, 2.2.1.3	2.7 MPa (vacuum press) 4.4 MPa (hydraulic press)
<b>HBS Brettsperrholz</b>		Annex 2	
Characteristic data of cross laminated timber		of European Technical Assessment ETA-20/0860 of 27.03.2023	



electronic copy electronic copy electronic copy electronic copy electronic copy electronic copy electronic copy electronic copy electronic copy electronic copy

BWR	Essential characteristic	Assessment method	Level / Class / Description
6	<b>Energy economy and heat retention</b>		
	Thermal conductivity, $\lambda$ , of wood	EN ISO 10456	0.12 W/(m·K)
	Thermal inertia, specific heat capacity $c_p$ , of wood	EN ISO 10456	1 600 J/(kg·K)
<b>HBS Brettsperrholz</b>		Annex 2	
Characteristic data of cross laminated timber		of European Technical Assessment ETA-20/0860 of 27.03.2023	





## Mechanical actions perpendicular to plane and in plane of cross laminated timber

### General

Due to the perpendicular orientation of the boards, cross laminated timber is able to transfer loads in all directions according to its condition of support. For cross laminated timber multi-axle stressed in both principal directions, different stiffness for the two principal directions shall be considered.

For calculation of characteristic values of cross-section, only boards which are oriented in direction of the mechanical action may be employed.

For design of cross laminated timber according to EN 1995-1-1, characteristic strength and stiffness of solid wood according to Annex 2 shall be taken.

### Mechanical actions perpendicular to cross laminated timber

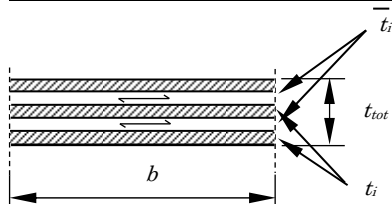

Where

$t_i$ ..... Thickness of board layers in direction of mechanical actions

$\bar{t}_i$ ..... Thickness of board layers perpendicular to direction of mechanical actions

The bending stiffness is specified in relation to the effective moment of inertia  $I_{eff}$ .

The calculation of the effective moment of inertia and therewith of the effective bending stiffness is according to EN 1995-1-1.

For  $I_{eff}$  see clause 9.1.3 and Annex B of EN 1995-1-1.

The term  $\frac{S_i}{K_i}$  of EN 1995-1-1 should be substituted by  $\frac{\bar{t}_i}{G_{9090} \cdot b}$ .

$$I_i = \frac{b \cdot t_i^3}{12}$$

$$W_{eff} = \frac{2 \cdot I_{eff}}{t_{tot}}$$

$$A_i = b \cdot t_i$$

$$h_{tot} = \sum_i (t_i + \bar{t}_i)$$

$$\tau_{v,d} = \frac{1.5 \cdot V_d}{A_{gross}}$$

$$A_{gross} = b \cdot t_{tot}$$

Where

$I$ ..... moment of inertia

$I_{eff}$ ..... effective moment of inertia

$s$ ..... spacing of fasteners according to EN 1995-1-1 (*not relevant for solid wood slab*)

$K$ ..... slip modulus according to EN 1995-1-1 (*not relevant for solid wood slab*)

$G_{9090}$ ..... shear modulus of the board perpendicular to grain (*rolling shear modulus*);  $G_{9090} = 50$  MPa

$b$ ..... width of the member of cross laminated timber

**HBS Brettsperrholz**

Annex 4

Resistance to fire

of European Technical Assessment  
ETA-20/0860 of 27.03.2023

Mechanical actions in plane of the solid wood slab

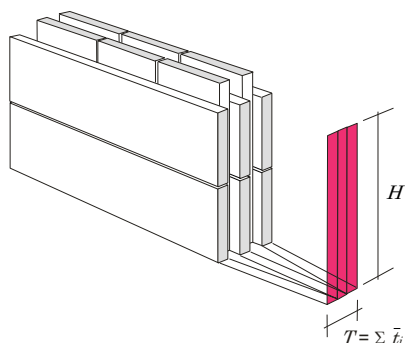

Where

$H \leq 400$  mm

$t_i$ ..... Thickness of board layers in direction of mechanical actions

$\bar{t}_i$ ..... Thickness of board layers perpendicular to direction of mechanical actions

$V$ ..... Shear force

Under the terms of the technical beam theory the following equations may be used.

Moment of inertia

$$I_{net} = \frac{T \cdot H^3}{12}$$

Section modulus

$$W_{net} = \frac{T \cdot H^2}{6}$$

Shear stress

$$\tau_{v,d} = \text{Maximum} \begin{cases} \frac{3}{2} \cdot \frac{V_d}{A_{x,net}} \\ \frac{3}{2} \cdot \frac{V_d}{A_{z,net}} \end{cases}$$

$$A_{x,net} = H \cdot \sum_i \bar{t}_i$$

$$A_{z,net} = H \cdot \sum_i t_i$$

**HBS Brettsperrholz**

Annex 4

Resistance to fire

of European Technical Assessment  
 ETA-20/0860 of 27.03.2023

